

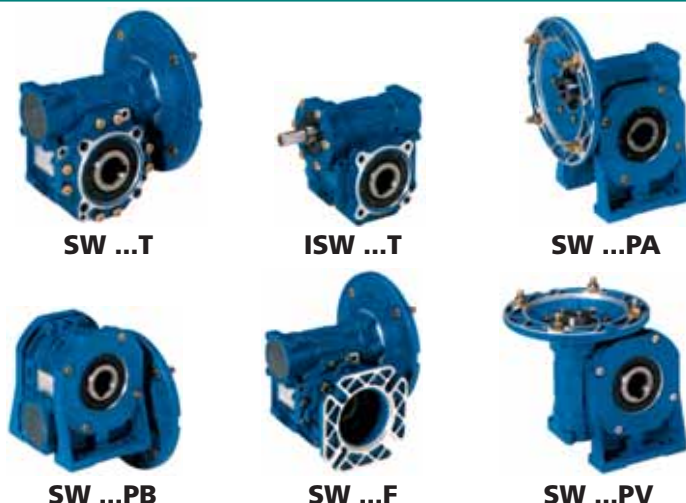

Riduttori a vite senza fine - serie «SW»

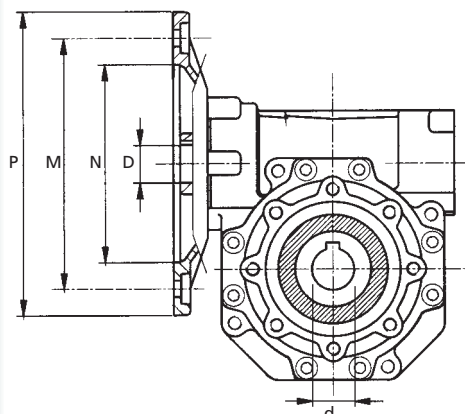

Tipo	PAM <input type="checkbox"/> IEC	N mm	M mm	P mm	Rapporti di riduzione												d mm
					D mm												
					5	7,5	10	15	20	25	30	40	50	60	80	100	
SW 030	63B5	95	115	140	11	11	11	11	11	11	11	11	11	-	-	-	-
	63B14	60	75	90													
	56B5	80	100	120	9	9	9	9	9	9	9	9	9	9	9	-	
	56B14	50	65	80													
SW 040	71B5	110	130	160	14	14	14	14	14	14	14	14	-	-	-	-	18 (19)
	71B14	70	85	105													
	63B5	95	115	140	11	11	11	11	11	11	11	11	11	11	11	11	
	63B14	60	75	90													
SW 050	56B5	80	100	120	-	-	-	-	-	-	-	-	9	9	9	9	25 (24)
	80B5	130	165	200	19	19	19	19	19	19	19	-	-	-	-	-	
	80B14	80	100	120													
	71B5	110	130	160	14	14	14	14	14	14	14	14	14	14	14	-	
SW 063	63B5	95	115	140	-	-	-	-	-	-	-	11	11	11	11	11	25 (28)
	90B5	130	165	200	-	24	24	24	24	24	24	-	-	-	-	-	
	90B14	95	115	140													
	80B5	130	165	200	-	19	19	19	19	19	19	19	19	19	-	-	
SW 075	80B14	80	100	120	-	-	-	-	-	-	-	14	14	14	14	14	28 (35)
	71B5	110	130	160	-	-	-	-	-	-	-	14	14	14	14	14	
	100/112B5	180	215	250	-	28	28	28	-	-	-	-	-	-	-	-	
	100/112B14	110	130	160													
	90B5	130	165	200	-	24	24	24	24	24	24	24	-	-	-	-	
	90B14	95	115	140													
SW 090	80B5	130	165	200	-	-	-	-	-	-	-	14	14	14	14	14	35 (38)
	80B14	80	100	120	-	-	-	-	-	-	-	19	19	19	19	19	
	100/112B5	180	215	250	-	28	28	28	28	28	28	-	-	-	-	-	
	100/112B14	110	130	160													
SW 105	90B5	130	165	200	-	24	24	24	24	24	24	24	24	24	24	24	-
	80B5	130	165	200	-	-	-	-	-	-	-	-	-	-	-	-	
	132B5	230	265	300	-	38*	38*	38*	38*	-	-	-	-	-	-	-	
	100/112B5	180	215	250	-	28	28	28	28	28	28	28	28	28	-	-	
SW 110	90B5	130	165	200	-	-	-	-	-	24	24	24	24	24	24	24	-
	80B5	130	165	200	-	-	-	-	-	-	-	-	-	-	19	19	
	132B5	230	265	300	-	38*	38*	38*	38*	-	-	-	-	-	-	-	
	100/112B5	180	215	250	-	28	28	28	28	28	28	28	28	28	-	-	
SW 130	90B5	130	165	200	-	-	-	-	-	-	-	-	-	-	24	24	-
	100/112B5	180	215	250	-	-	-	-	-	28	28	28	28	28	28	28	
	132B5	230	265	300	-	38*	38*	38*	38*	38*	38*	38*	-	-	-	-	
SW 150	160B5	250	300	350	-	42	42	42	42	42	-	-	-	-	-	-	-
	132B5	230	265	300	-	-	-	-	38	38	38	38	38	38	-	-	
	100/112B5	180	215	250	-	-	-	-	-	-	-	-	28	28	28	28	

Predisposizione attacco motore
* Linguetta ribassata

Dati non impegnativi